

Model DBWR Series

S-Beam Load Cell (500kg ~ 5t)



The DBWR S-beam load cell is designed for industrial scale conversion and a variety of process applications.

- 17-4PH stainless steel construction for high accuracy and corrosion resistance.
- Fully welded seal with stainless steel cover for hostile environment applications.

SPECIFICATIONS

MODEL	DBWR
Rated capacity (R.C.)	500kg, 1, 2, 3, 5t
Rated output(R.O.)	2mV/V \pm 0.3%
Non-linearity	\leq 0.03% R.O.
Hysteresis	\leq 0.03% R.O.
Non-repeatability	\leq 0.02% R.O.
Creep error	\leq 0.03% in 20min.
Zero balance	\leq 1% R.O.
Compensated temperature range	-10 ~ 70°C
Operating temperature range	-20 ~ 80°C
Temp. effect on rated output	\leq 0.03% LOAD/10°C
Temp. effect on zero balance	\leq 0.03% R.O./10°C
Terminal input resistance	350 Ohms \pm 3.5 Ohms
Terminal output resistance	350 Ohms \pm 5 Ohms
Insulation resistance (Min.)	2000 MOhms at 50V DC
Excitation voltage	10V(Recommended), 15V(Max.)
Electrical connection	\varnothing 5mmx3m(22AWG x 4Core Shielded)
Protection class	meets IP 68
Safe overload	150% R.C
Ultimate overload	300% R.C

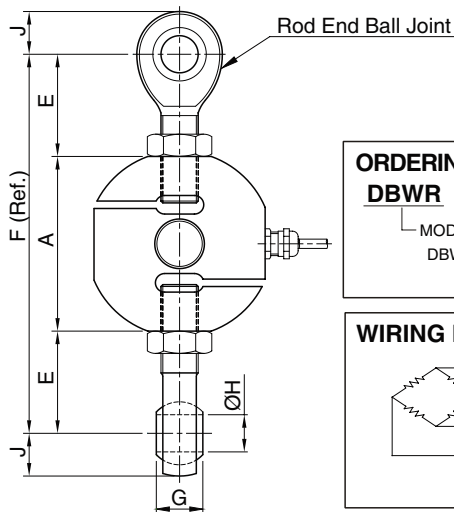
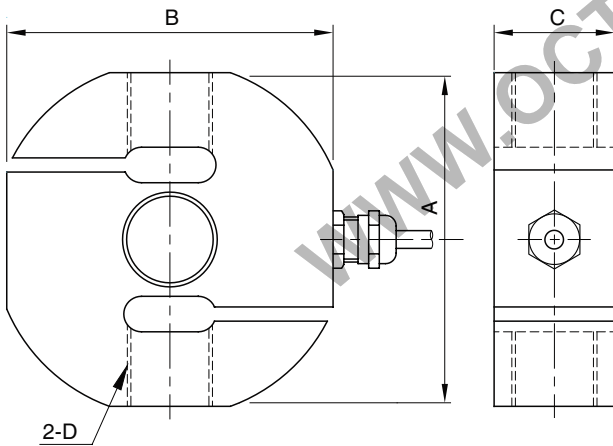

ORDERING INFORMATION

DBWR - 2T

MODEL DBWR CAPACITY 500kg, 1, 2, 3, 5 ton

WIRING INFORMATION

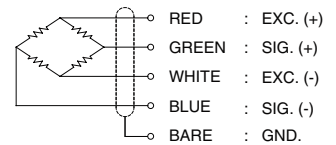

Dimension-mm

Rated Capacity	A	B	C	D	E	F	G	H	J	Rod End Ball Joints	Weight (kg)
500kg, 1t (4.903, 9.807kN)	76	76	30	M12x1.75P	41	158	16	12	16	SRDB 2	1.1
2t (19.61kN)	94	94	32	M20x1.5P	55	204	25	20	23	SRDB 3	1.6
3t (29.42kN)	114	114	34	M24x2P	55	224	28	22	32	SRDB 4	2.6
5t (49.03kN)	114	114	40	M24x2P	55	224	28	22	32	SRDB 4	3.1

* Specifications are subject to change without notice

JAN, 2010