

Model CWFK Series

Center Hole Type Load Cell
(10t ~ 200t)

- Robust high capacity design
- Alloy steel construction
- Fully welded seal

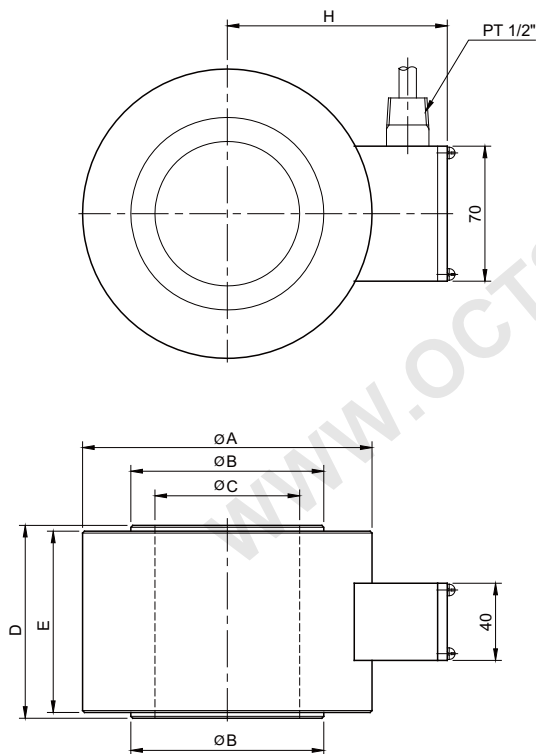

SPECIFICATIONS

MODEL	CWFK
Rated capacity (R.C.)	10, 20, 50, 100, 150, 200t
Rated output(R.O.)	1.0mV/V \pm 0.3%
Non-linearity	\leq 1.0% R.O.
Hysteresis	\leq 1.0% R.O.
Non-repeatability	\leq 1.0% R.O.
Creep error	\leq 0.1% in 20min.
Zero balance	\leq 1% R.O.
Compensated temperature range	-10 ~ 70°C
Operating temperature range	-20 ~ 80°C
Temp. effect on rated output	\leq 0.05% LOAD/10°C
Temp. effect on zero balance	\leq 0.05% R.O./10°C
Terminal input resistance	350 Ohms \pm 3.5 Ohms
Terminal output resistance	350 Ohms \pm 5 Ohms
Insulation resistance (Min.)	2000 MOhms at 50V DC
Excitation voltage	10V(Recommended), 15V(Max.)
Electrial connection	ϕ 7mmx6m(22AWG x 4Core Shielded)
Protection class	meets IP 67
Safe overload	150% R.C
Ultimate overload	300% R.C

ORDERING INFORMATION

CWFK - 50T

MODEL	CAPACITY
CWFK	10, 20, 50, 100, 150, 200t

WIRING INFORMATION

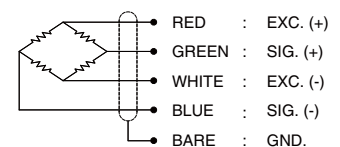

Dimension-mm

Rated Capacity	A	B	C	D	E	H	Weight (kg)
10, 20t (98.07, 196.1kN)	88	48	30	80	74	76	1.6
50t (490.3 kN)	110	70	40	80	74	87	3.0
100t (980.7 kN)	138	100	60	110	100	101	6.2
150t (1471kN)	164	126	80	130	120	114	11.6
200t (1961kN)	190	152	100	150	140	127	18.0

* Specifications are subject to change without notice

AUG, 2012